

# STEREO CASSETTE DECK

# K-2000

## SERVICE MANUAL

### FRONT PANEL

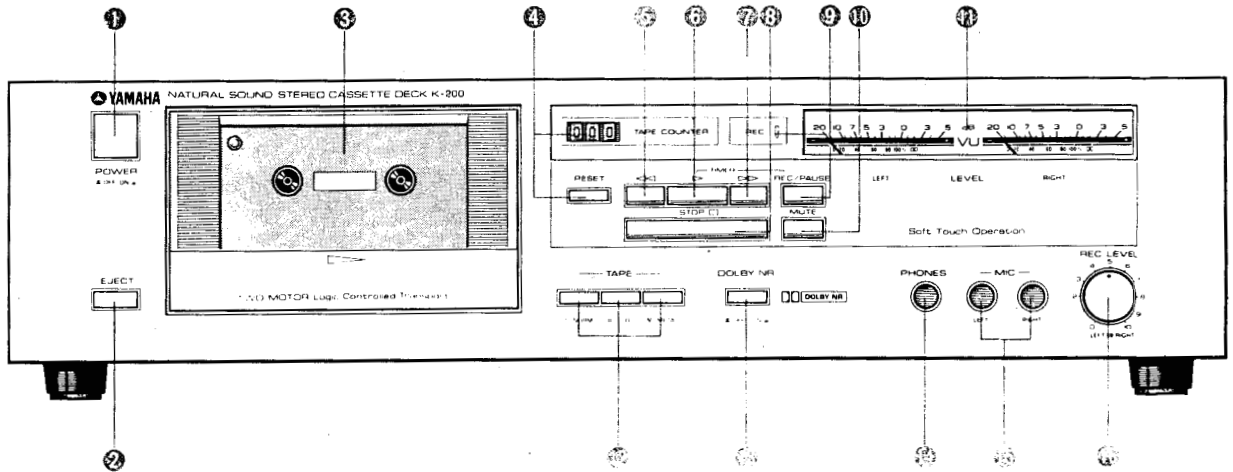

- |  |   |
|--|---|
| ① Power Switch (POWER)                           | ⑩ Record-Standby/Pause Button (REC/PAUSE) |
| ② Eject Button (EJECT)                           | ⑪ Record-Muting Button (MUTE)             |
| ③ Cassette Holder                                | ⑫ VU Level Meters (LEVEL)                 |
| ④ Tape Counter/Reset Button (TAPE COUNTER/RESET) | ⑬ Tape Selector Switches (TAPE)           |
| ⑤ Rewind Button ( << )                           | ⑭ Dolby NR Switch (DOLBY NR)              |
| ⑥ Play Button ( > )                              | ⑮ Headphone Jack (PHONES)                 |
| ⑦ Fast-Forward Button ( >> )                     | ⑯ Microphone Jacks (MIC)                  |
| ⑧ Stop Button ( □ )                              | ⑰ Record Level Control (REC LEVEL)        |

### CONTENTS

Rear Panel .....	1
Names of the Parts .....	2
Disassembly Instructions .....	3
General Adjustments .....	4
Specifications .....	7
Block Diagram .....	7
Performance Chart for Mechanism Logic .....	8
Printed Circuit Board Pattern-side Layout .....	10
Printed Circuit Board Parts-side Components Layout/Wiring .....	11
Schematic Diagram .....	12

004463

SINCE 1887



**YAMAHA**

NIPPON GAKKI CO., LTD. HAMAMATSU, JAPAN

Printed in Japan 5.82 2.65K

REAR PANEL

U.S.A. and Canadian Models

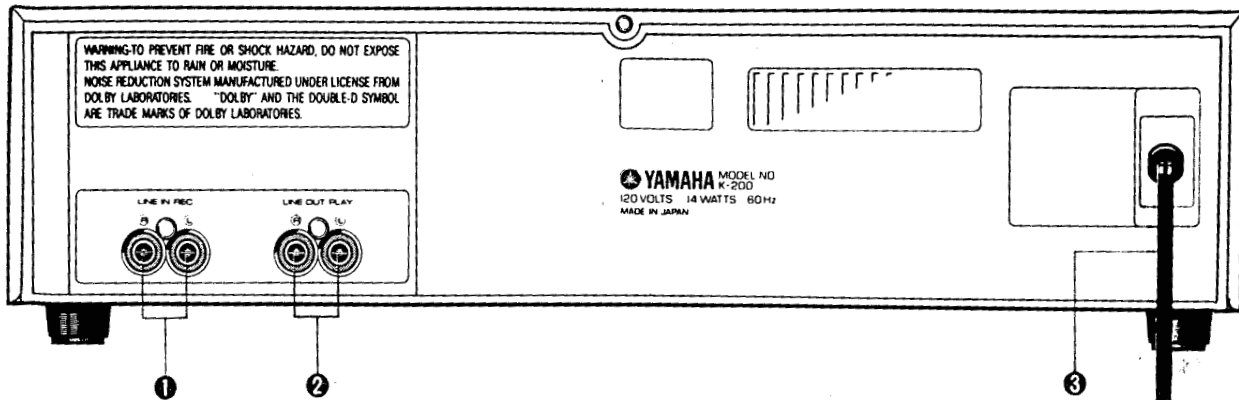

- ① Record Input Jacks (LINE IN/REC)
- ② Playback Output Jacks (LINE OUT/PLAY)
- ③ Power Cord

Australian and British Models

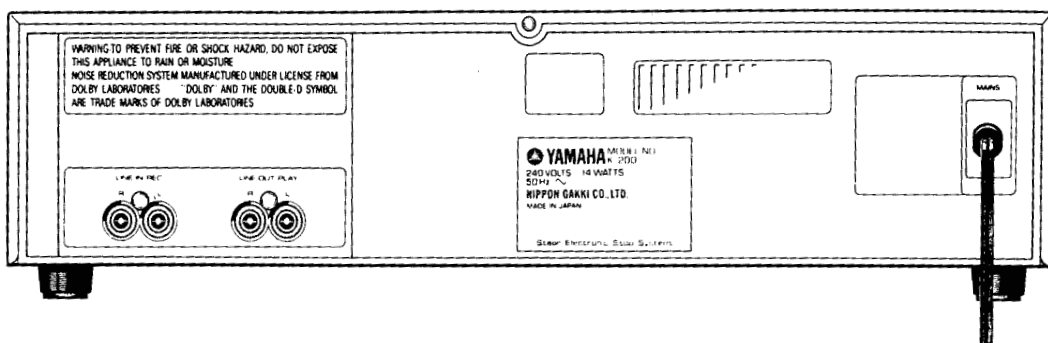

European Model

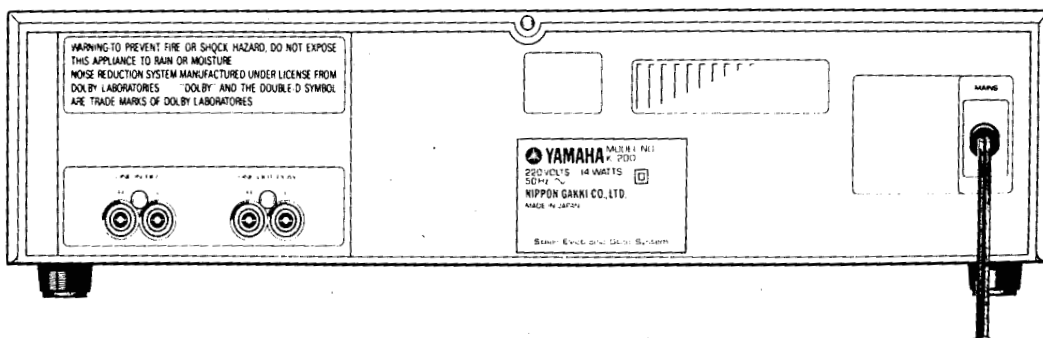

General Model

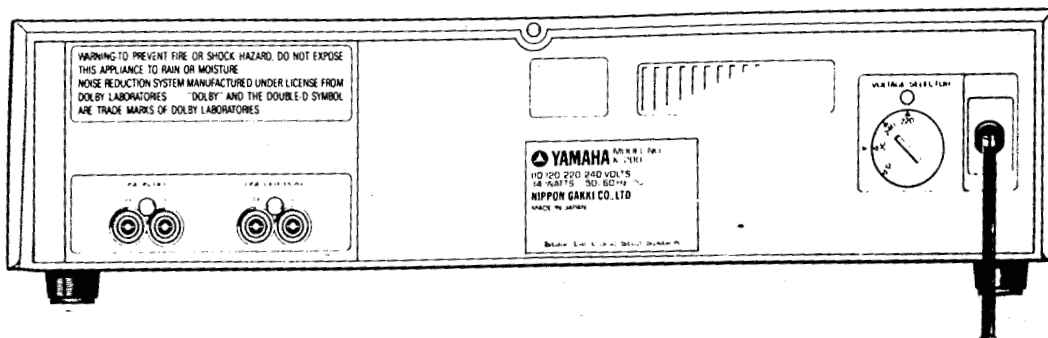

## ■ NAMES OF THE PARTS

Top View

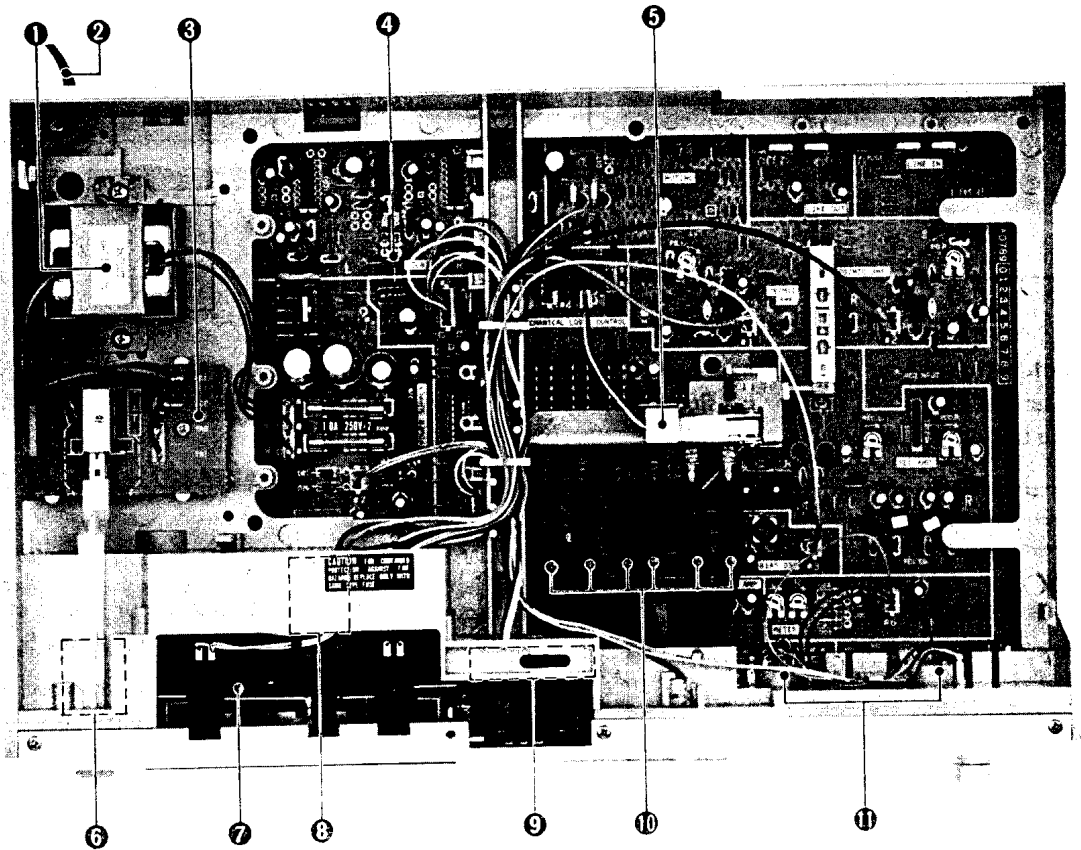

- ① Power transformer
- ② Power cord
- ③ Main circuit board (2)
- ④ Main circuit board (1)
- ⑤ Auto-Shut off solenoid
- ⑥ Capstan drive motor
- ⑦ Transport mechanism TM-5A
- ⑧ Reel drive motor
- ⑨ Main circuit board (3)
- ⑩ Switch rods
- ⑪ VU meters

**DISASSEMBLY INSTRUCTIONS**

**1. Removal of Top Cover**

Remove screws ① and ② shown in photo 1 (4 screws each right and left) and remove plastic rivet ⑤. The top cover can now be removed.

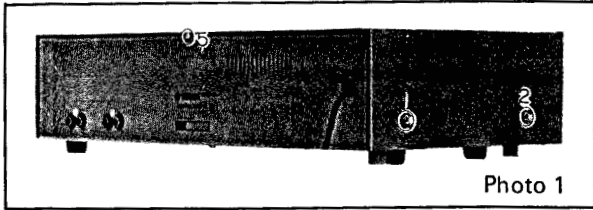

**2. Removal of Bottom Cover**

Remove screws ① ~ ⑧ shown in fig 2, and remove the bottom cover.

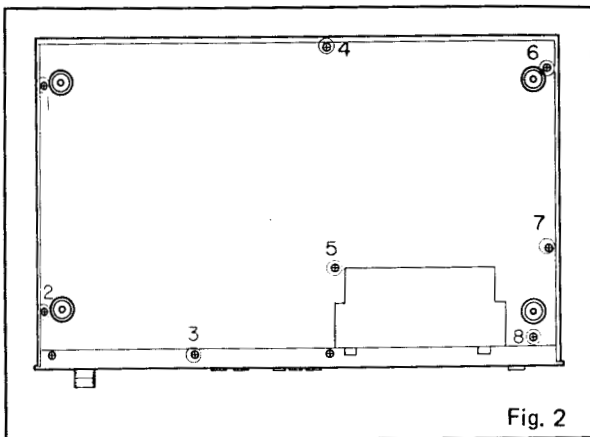

**3. Removal of Front Panel**

- a) Remove the top and bottom covers per steps 1, and 2.
- b) Remove screws ① ~ ⑥ shown in photo 3, and remove the front panel.

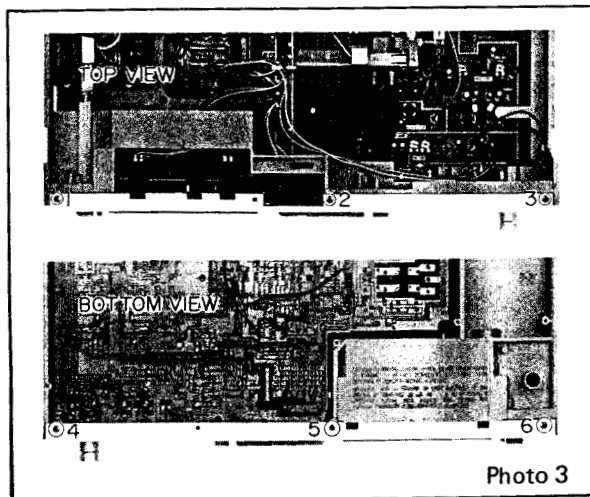

**4. Removal of Transport Mechanism**

- a) Remove the front panel according to step 3.
- b) Remove the cassette cover.
- c) Unplug all connectors from the mechanism section.
- d) Remove screws ① ~ ④ shown in photo 4, and remove the transport mechanism.

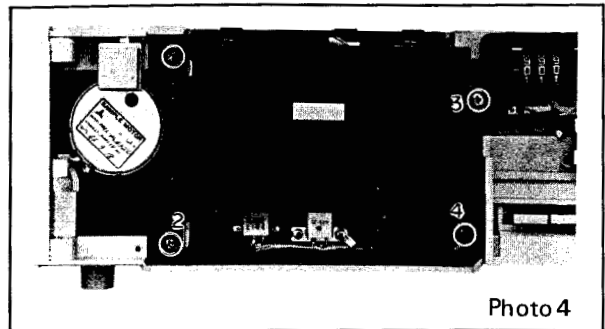

**5. Removal of VU Meters**

- a) Remove the front panel according to step 3.
- b) Remove screw ① shown in photo 5, and remove the VU meters.

**6. Removal of Circuit Board**

- a) Remove the top and bottom covers and the front panel according to steps 1, 2 and 3.
- b) Remove screws ② and ③ shown in photo 5.
- c) Remove the plastic rivets A and B shown in photo 6.
- d) Remove screw ① shown in photo 7, and remove plastic rivets A ~ C.
- e) After removing all switch rods, the circuit board can be detached.

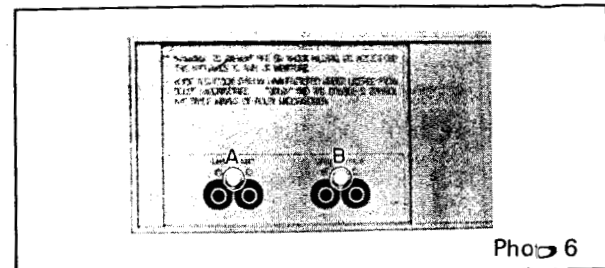
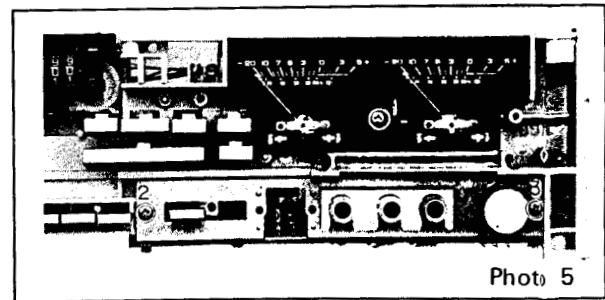

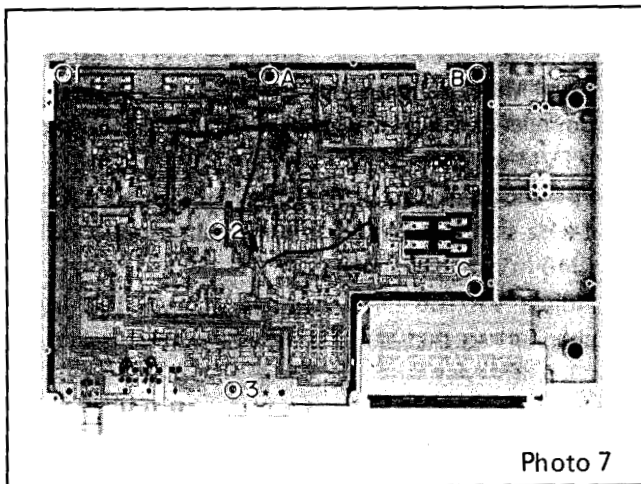

Photo 7

## ■ GENERAL ADJUSTMENTS

### Before Adjustment

1. Set the Dolby NR switch to OFF.
2. As dirty or magnetized heads can deteriorate measurement results for various parameters, be sure to perform head demagnetizing and head cleaning, especially before adjusting frequency response or head azimuth.

### Designated Test Tapes

TEAC . . . . .	MTT-111 (3 kHz)
TEAC . . . . .	MTT-212C (160 nWb/m) or MTT-212 (250 nWb/m)
TEAC . . . . .	MTT-114 (10 kHz)
TEAC . . . . .	MTT-216 (3180 + 120 $\mu$ s) or MTT-316 (3180 + 70 $\mu$ s)
TDK . . . . .	SA C-60 (CrO <sub>2</sub> tape)
TDK . . . . .	AD C-60 (LH tape)
TDK . . . . .	MA C-60 (Metal tape)

### Playback Adjustments

#### 1. Tape Speed Adjustment

- a) Connect a frequency counter to the left or right channel LINE OUT.
- b) Play test tape TEAC MTT-111 (3 kHz) and adjust the semi-fixed VR in the drive motor base for a frequency counter reading of 3000 Hz  $\pm 15$  Hz.

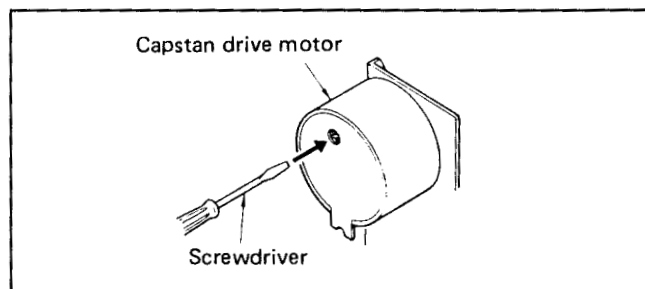
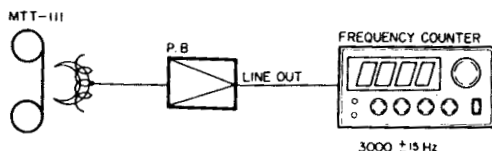

#### 2. Playback Level Adjustment

- a) Connect a VTVM to LINE OUT.
- b) Play test tape TEAC MTT-212C (160 nWb/m) and adjust VR 101 (left channel) and VR 102 (right channel) for a LINE OUT level reading of  $-7 \pm 1$  dBm (346 mV).

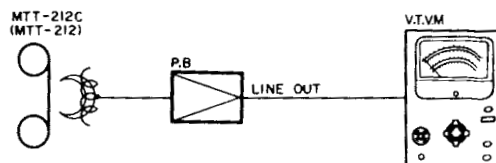

**3. Head Azimuth Adjustment**

- a) Remove the cassette cover.
- b) Connect two VTVMs and an oscilloscope to the left and right channels of LINE OUT.
- c) Play test tape TEAC MTT-114 (10 kHz) and turn the R/P head azimuth adjustment screw so that the outputs of both left and right channels are maximum, equal, and in phase.
- d) After adjustment, apply screw lock paint.

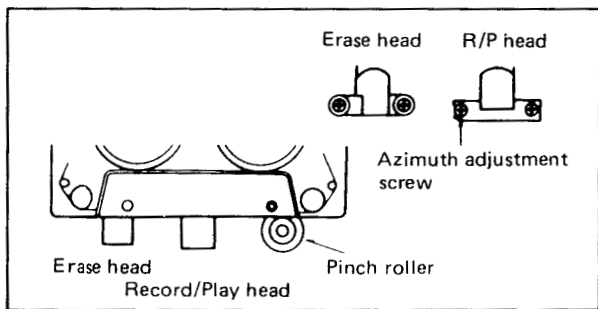
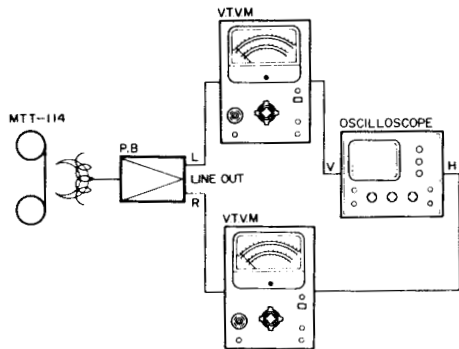

**4. Playback Frequency Response Check**

- a) Connect a VTVM to LINE OUT.
- b) Play test tape TEAC MTT-216 (3180 + 120 μs : LH) or MTT-316 (3180 + 70 μs : CrO<sub>2</sub>) and confirm that the 10-kHz reading is within ±3 dB of the 315-Hz reading.

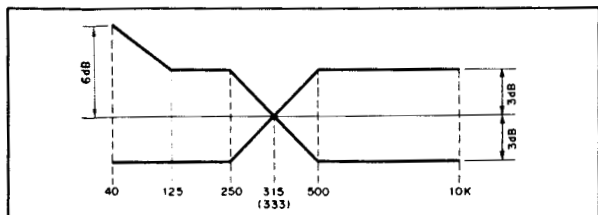
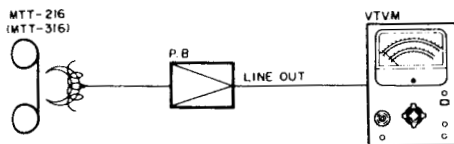

**Recording Adjustments**

**1. Level Meter Adjustment**

- a) Connect an audio oscillator to LINE IN and a VTVM to LINE OUT.
- b) Put the deck into the record mode and apply a 1-kHz signal to LINE IN which will cause -7 dBm (346 mV) at the LINE OUT.
- c) Adjust VR 105 (left channel) and VR 106 (right channel) so that the VU meter pointers read 0 dB ±1.5 dB.

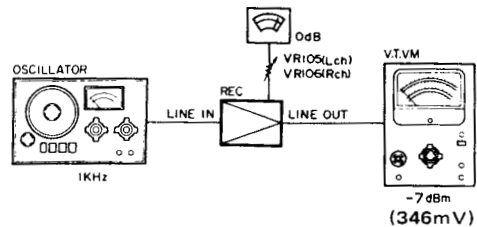

**2. Record Level Adjustment**

- a) Establish the same connections as for level meter adjustment, above.
- b) Put the deck into the record mode and apply a 315-Hz (1-kHz, 333-Hz) signal to LINE IN which will read -7 dBm (346 mV) at LINE OUT.
- c) Use the TDK SA C-60 CrO<sub>2</sub> tape and record this signal.
- d) Adjust VR 103 (left channel) and VR 104 (right channel) so that the recorded signal reads -7 dBm (346 mV) upon playback.

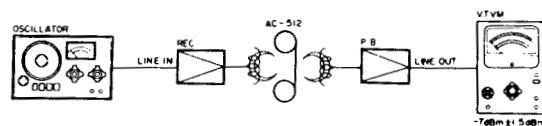

**3. Check of Recording Bias Current**

\* Set the DOLBY NR switch to OFF.

- a) Connect an audio oscillator to LINE IN and a VTVM and distortion meter to LINE OUT.
- b) Apply a signal to LINE IN which will read -27 dBm (34.6 mV, -20 VU) at LINE OUT.

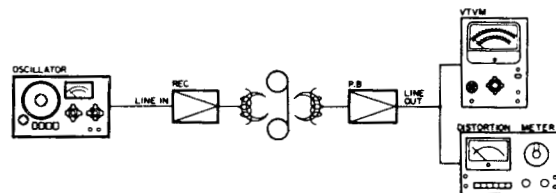

- CrO<sub>2</sub> Position
  - Use a TDK SA C-60 CrO<sub>2</sub> tape and adjust VC 101 (trimmer capacitor, L and R) so that the 14-kHz record/playback level is within  $\pm 3$  dB of the 1-kHz (315-Hz, 333-Hz) record/playback level.
  - At this time, distortion at 315-Hz (1-kHz, 333-Hz), 0 VU must be below 2.5%.

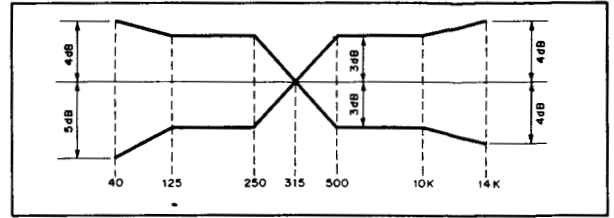
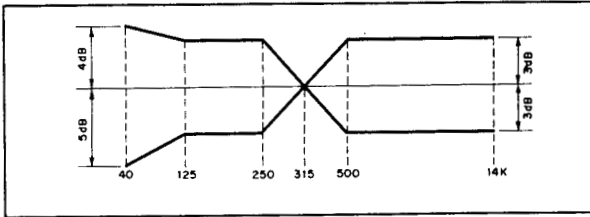

- METAL Position
  - Use a TDK MA C-60 metal tape and check that the 14-kHz record/playback level is within  $\pm 4$  dB of the 315-Hz (1-kHz, 333-Hz) record/playback level.

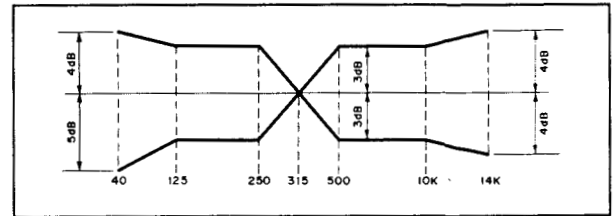

- LH Position
  - Use a TDK AD C-60 (LH) tape and check that the 14-kHz record/playback level is within  $\pm 4$  dB of the 315-Hz (1-kHz, 333-Hz) record/playback level.

### Location of Adjustment Points

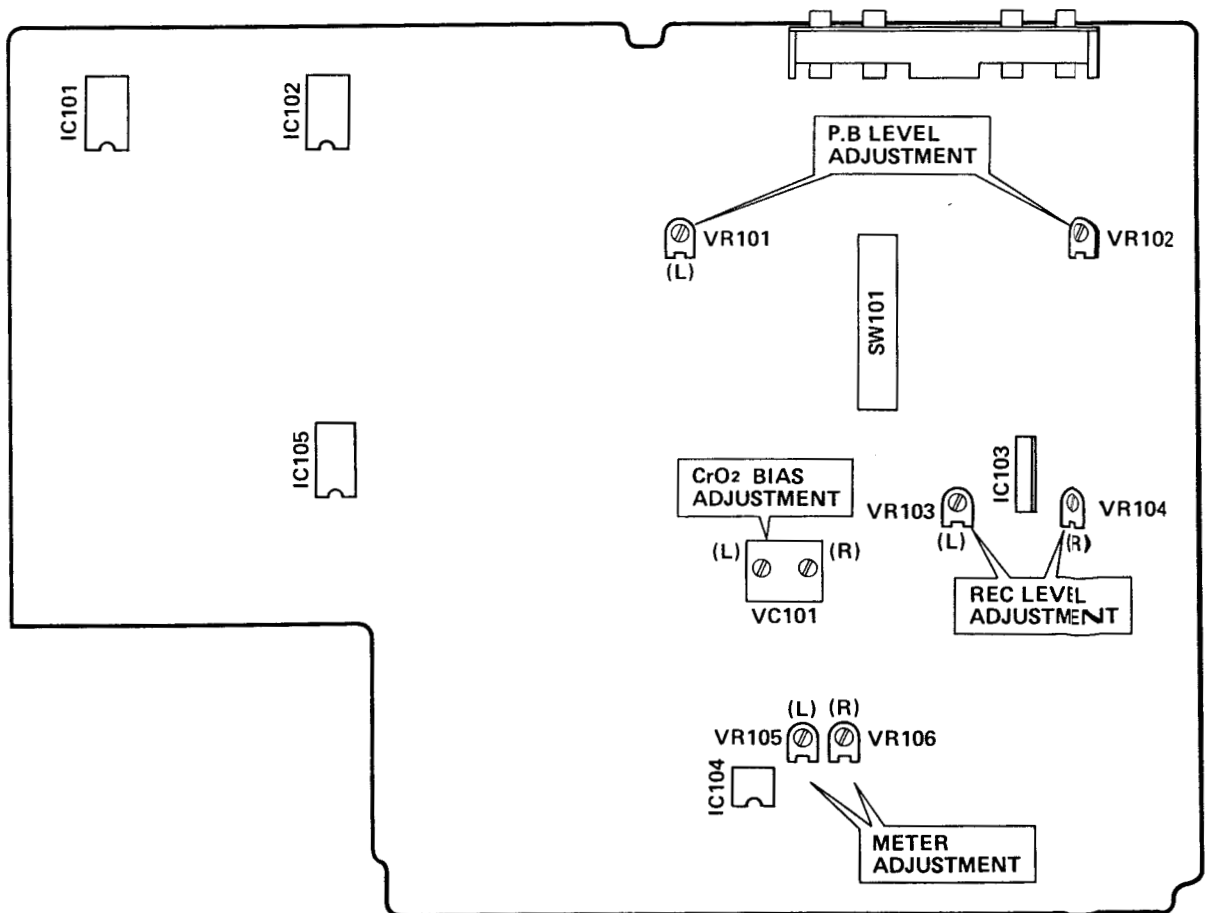

## SPECIFICATIONS

<b>Track Configuration</b> . . . . .	4 track, 2 channel stereo
<b>Motor</b> . . . . .	DC servo motor (capstan) Flat torque DC motor (reel)
<b>Heads</b> . . . . .	Hard permalloy rec/play- back head Double-gap ferrite erase head
<b>Tape Speed</b> . . . . .	4.75 cm/sec
<b>Wow and Flutter</b>	
WRMS . . . . .	0.05%
DIN-45507 . . . . .	0.08%
<b>Signal-to-Noise Ratio</b>	
(Dolby off, CrO <sub>2</sub> tape) . . . . .	better than 58 dB
(Dolby on, CrO <sub>2</sub> tape) . . . . .	better than 66 dB
<b>Frequency Response</b>	
Normal tape (-20 dB) . . . . .	40 ~ 15,000 Hz ± 3 dB
CrO <sub>2</sub> tape (-20 dB) . . . . .	40 ~ 15,000 Hz ± 3 dB
Metal tape (-20 dB) . . . . .	40 ~ 15,000 Hz ± 3 dB
(0 dB) . . . . .	40 ~ 12,000 Hz ± 3 dB
<b>Overall Distortion</b>	
Metal tape . . . . .	less than 1.0% (315 Hz)
<b>Channel Separation</b> . . . . .	better than 35 dB (1K Hz)
<b>Crosstalk</b> . . . . .	better than 60 dB (125 Hz)
<b>Erasure rate</b> . . . . .	better than 60 dB (400 Hz)

<b>Input Sensitivity/Impedance</b>	
<b>Mic</b> . . . . .	0.3mV/5K ohms
<b>Line</b> . . . . .	60 mV/80K ohms
<b>Output Level</b>	
<b>Line</b> . . . . .	350 mV/2.2K ohms
<b>Phones</b> . . . . .	0.6mW/8 ohms
<b>Power Supply</b>	
. . . . .	AC 120V, 60 Hz (U,C)
. . . . .	AC 220V, 50 Hz (G)
. . . . .	AC 240V, 50 Hz (A,B)
. . . . .	AC 110/120/220/240V, 50/60 Hz (R)
<b>Power Consumption</b> . . . . .	
. . . . .	14 W
<b>Dimensions (W x H x D)</b> . . . . .	
. . . . .	435 x 112 x 278 mm (17-1/8 x 4-13/32 x 11")
<b>Weight</b> . . . . .	
. . . . .	4.5 kg (9.9 lbs)

Specifications subject to change without notice.  
TM Dolby Laboratories Licensing Corp.

- U : U.S.A. Model
- C : Canadian Model
- R : General Model
- A : Australian Model
- B : British Model
- G : European Model

## BLOCK DIAGRAM

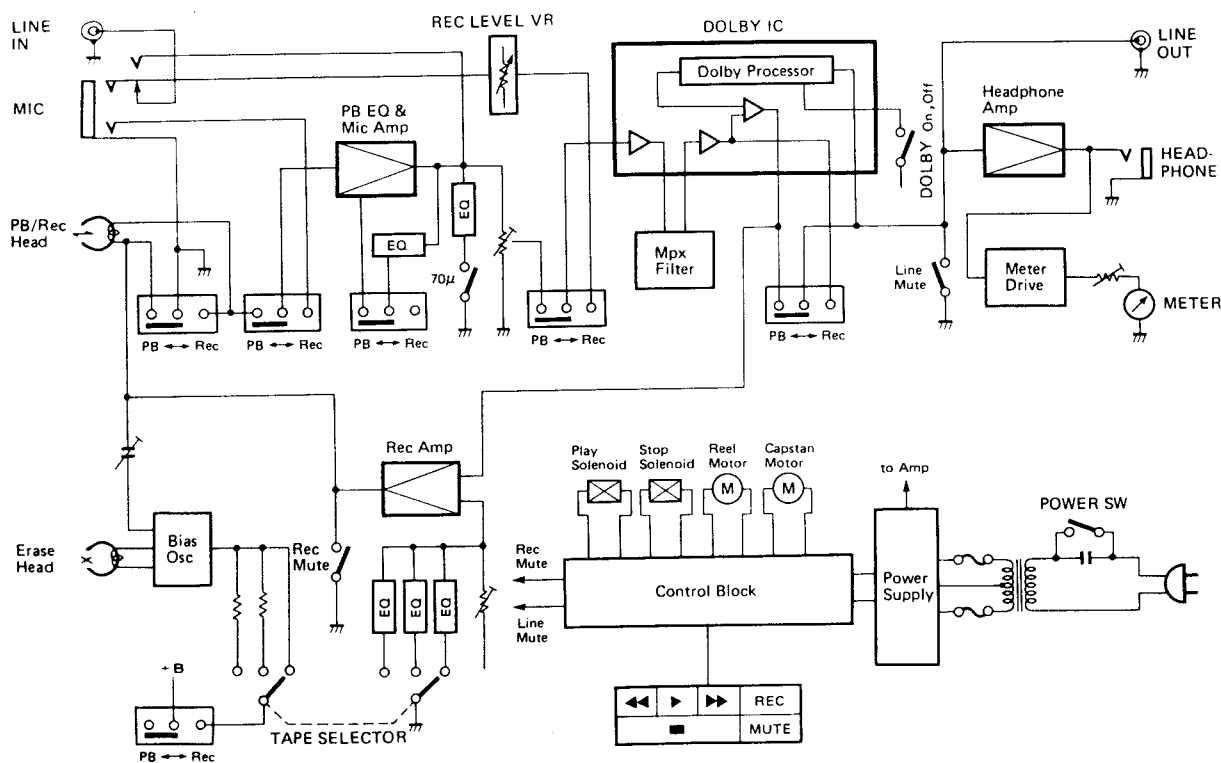



PERFORMANCE CHART FOR MECHANISM LOGIC

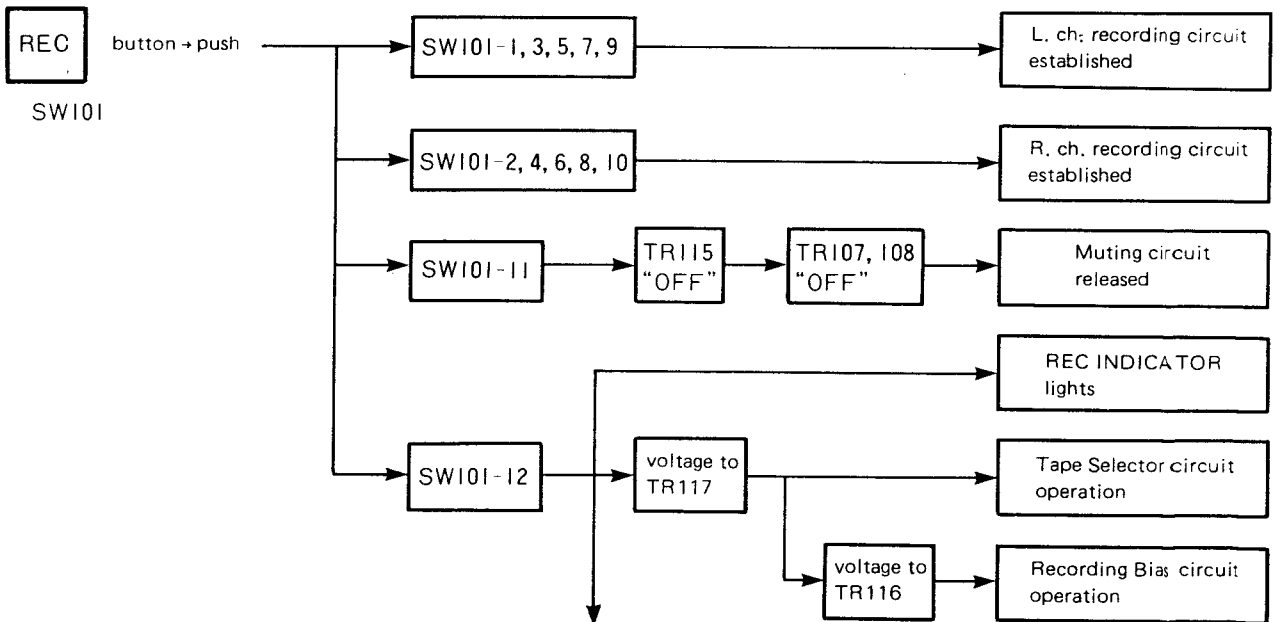
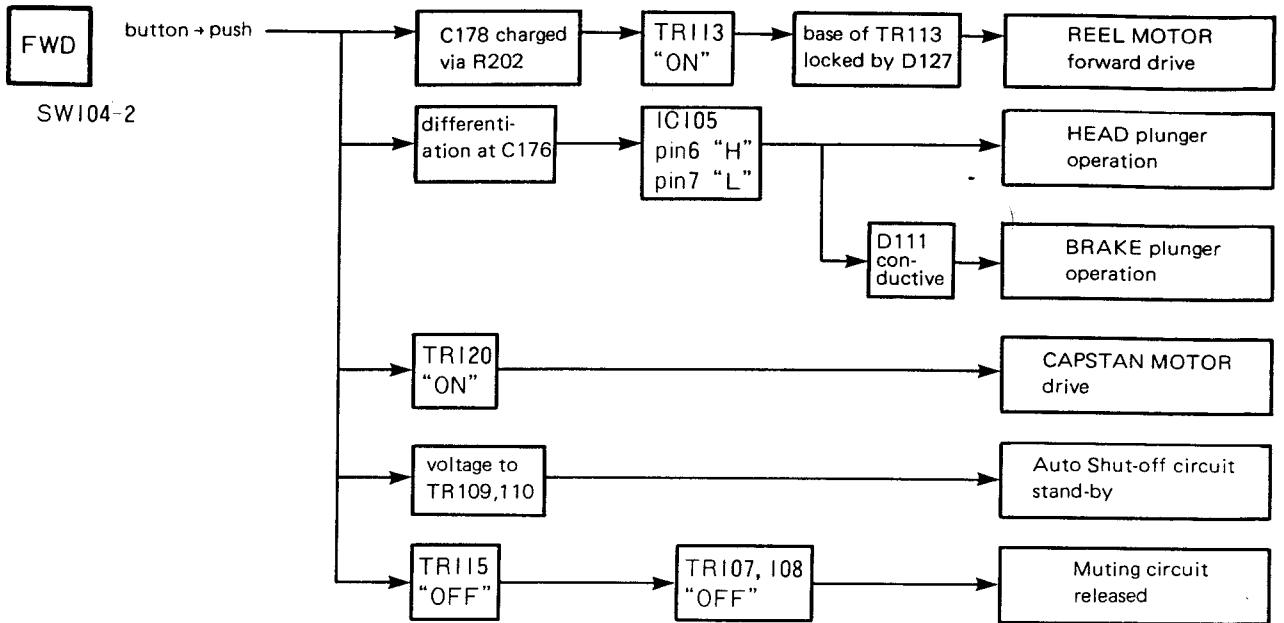

	Record Protection Tab	
	present	missing
REC IHN SW	open	closed
IC105 pin14	"L"	"H"
IC105 pin15	"H"	"L"

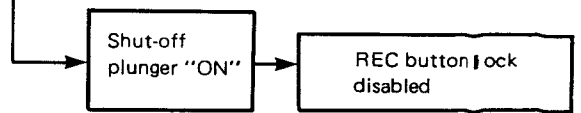

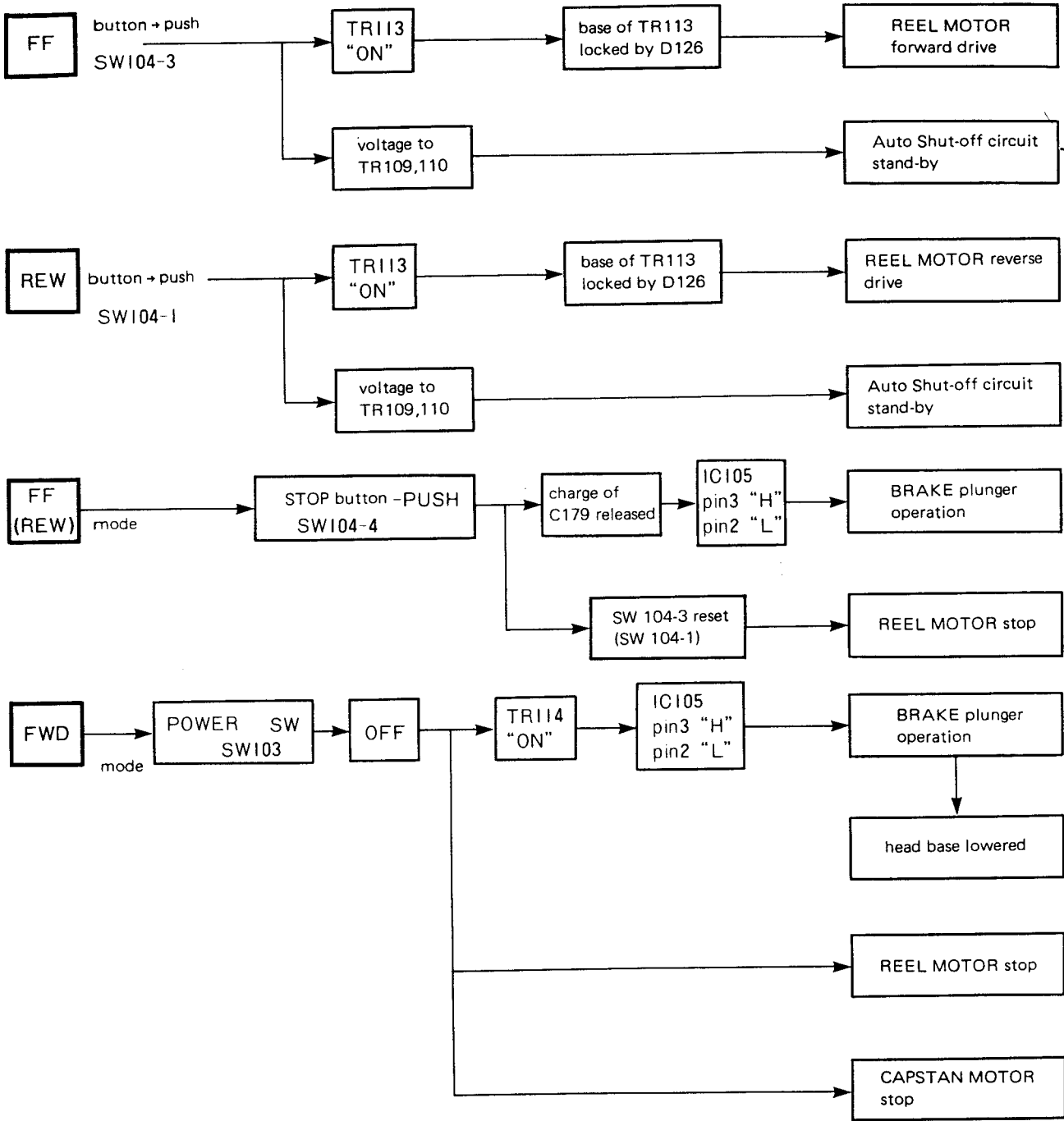

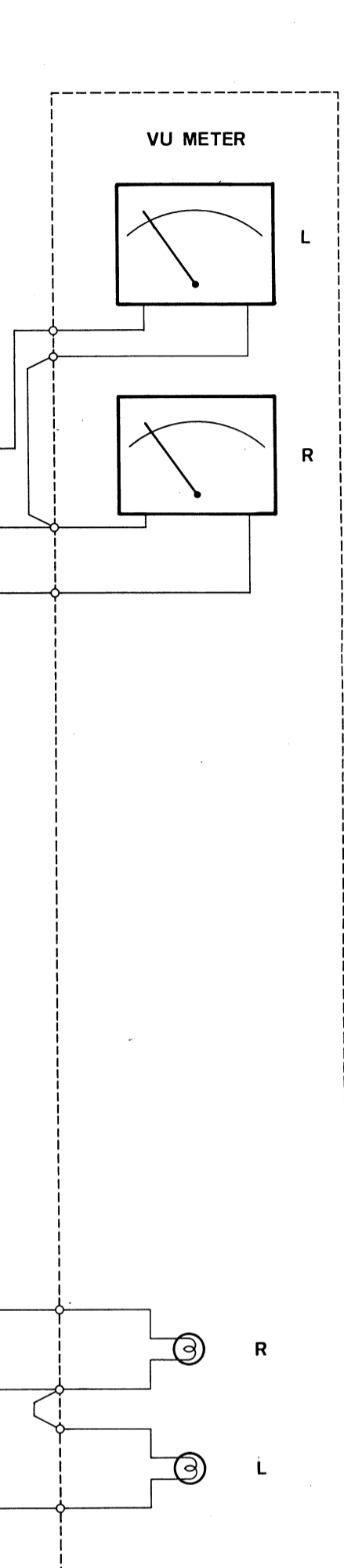
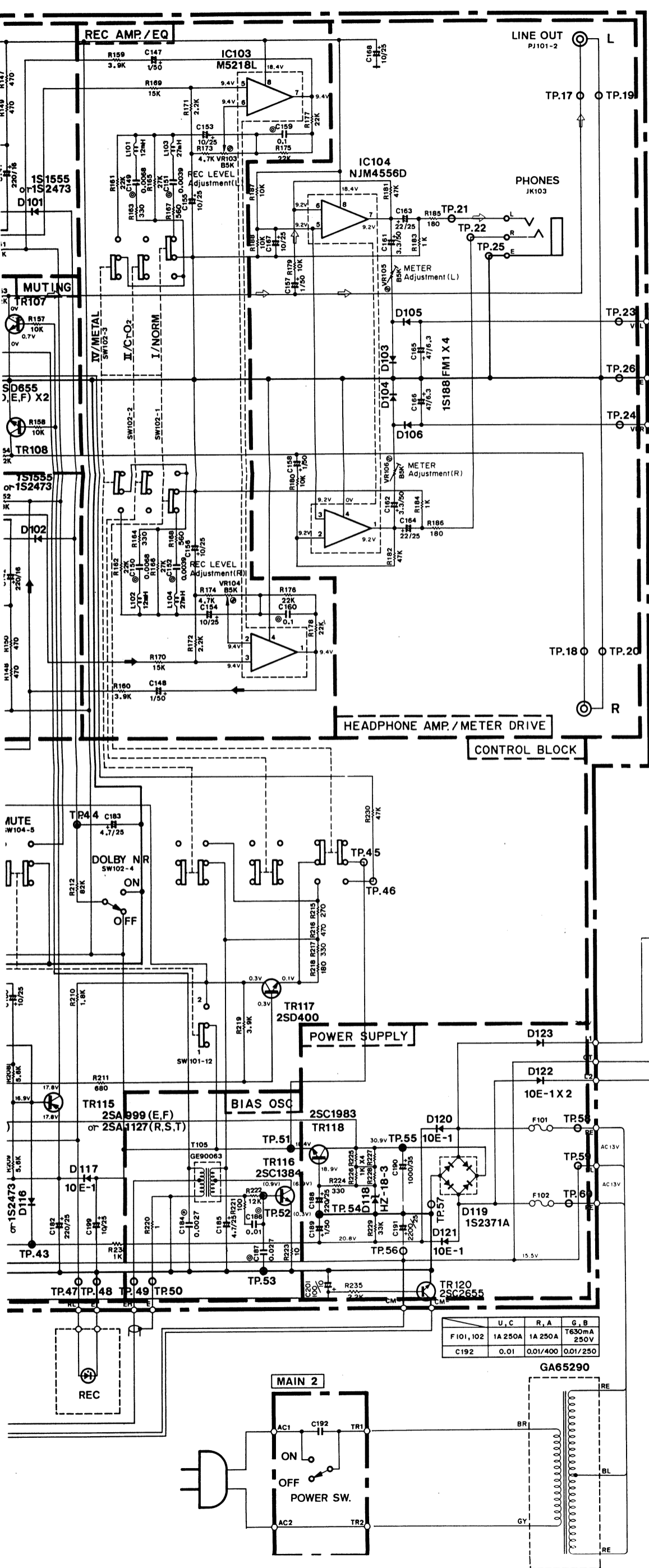

- 2SA999 2SC2634  
2SA1127 2SD400  
2SC1384 2SD655  
2SC2320
- 2SD880
- 2SC1983
- M5218L
- NJM4556D
- NE646N
- DN6838  
① +12(Vcc)  
② Ground  
③ Out
- Anode  
Cathode
- Anode  
Cathode  
DIODE
- 1S2371A

Note 1: Voltages shown in brackets are recording mode values, others are stop mode values.  
 Note 2: Voltages have been measured with a voltmeter of 1Mohms internal resistance.  
 Note 3: Signal path display:  
 → Left channel-playback signal  
 ← Right channel-recording signal  
 Note 4: Circuit diagram may be subject to change for improvement without further notice.

	U, C	R, A	G, B
F101, 102	1A 250A	1A 250A	T630mA 250V
C192	0.01	0.01/400	0.01/250

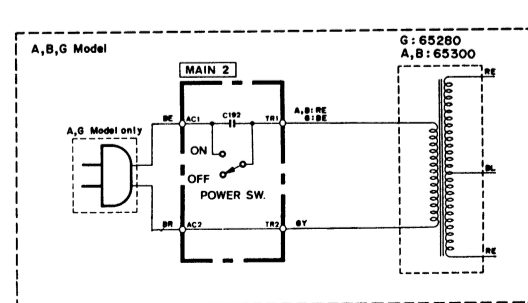
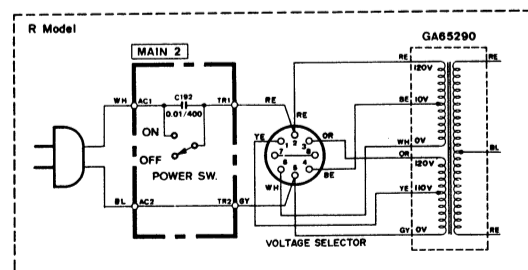

**SCHEMATIC DIAGRAM**

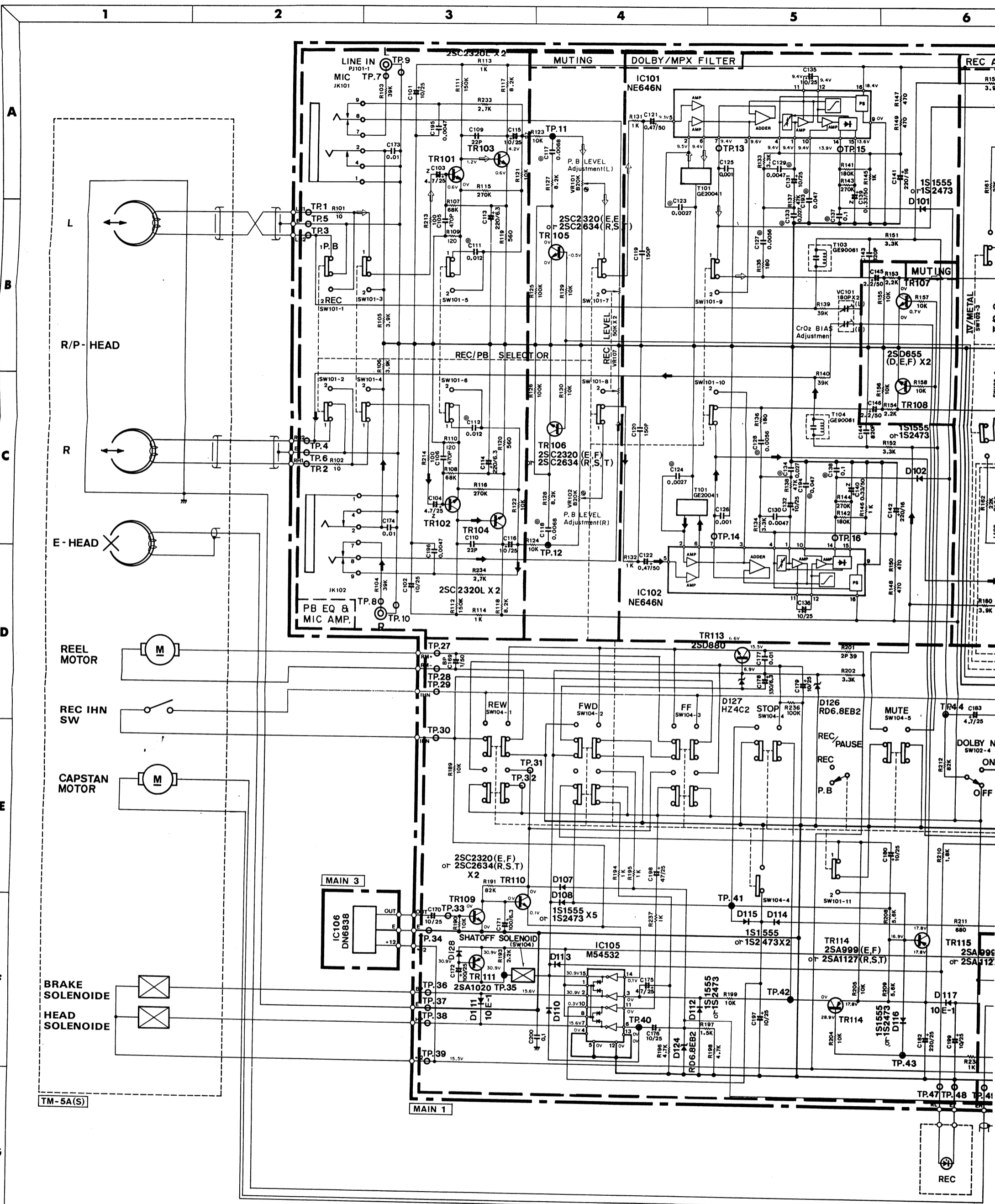

RESISTOR		CAPACITOR	
REMARKS	PARTS NAME	REMARKS	PARTS NAME
NO MARK	CARBON FILM RESISTOR	NO MARK	CERAMIC CAPACITOR
⊙	SEMI VARIABLE RESISTOR	⊙	POLYESTEL FILM CAPACITOR
		⊙	POLYPROPYLENE CAPACITOR
NO MARK		NO MARK	ELECTROLYTIC CAPACITOR
		BP	BYPOLAR CAPACITOR

H

PRINTED CIRCUIT BOARD PATTERN-SIDE LAYOUT

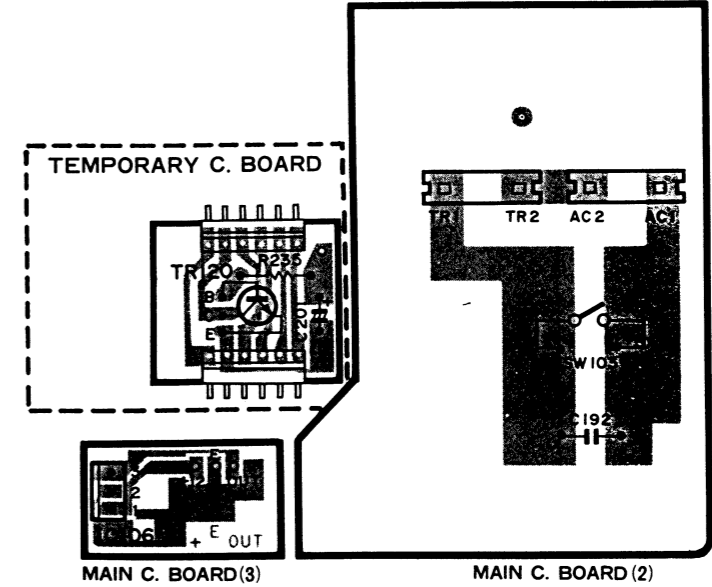
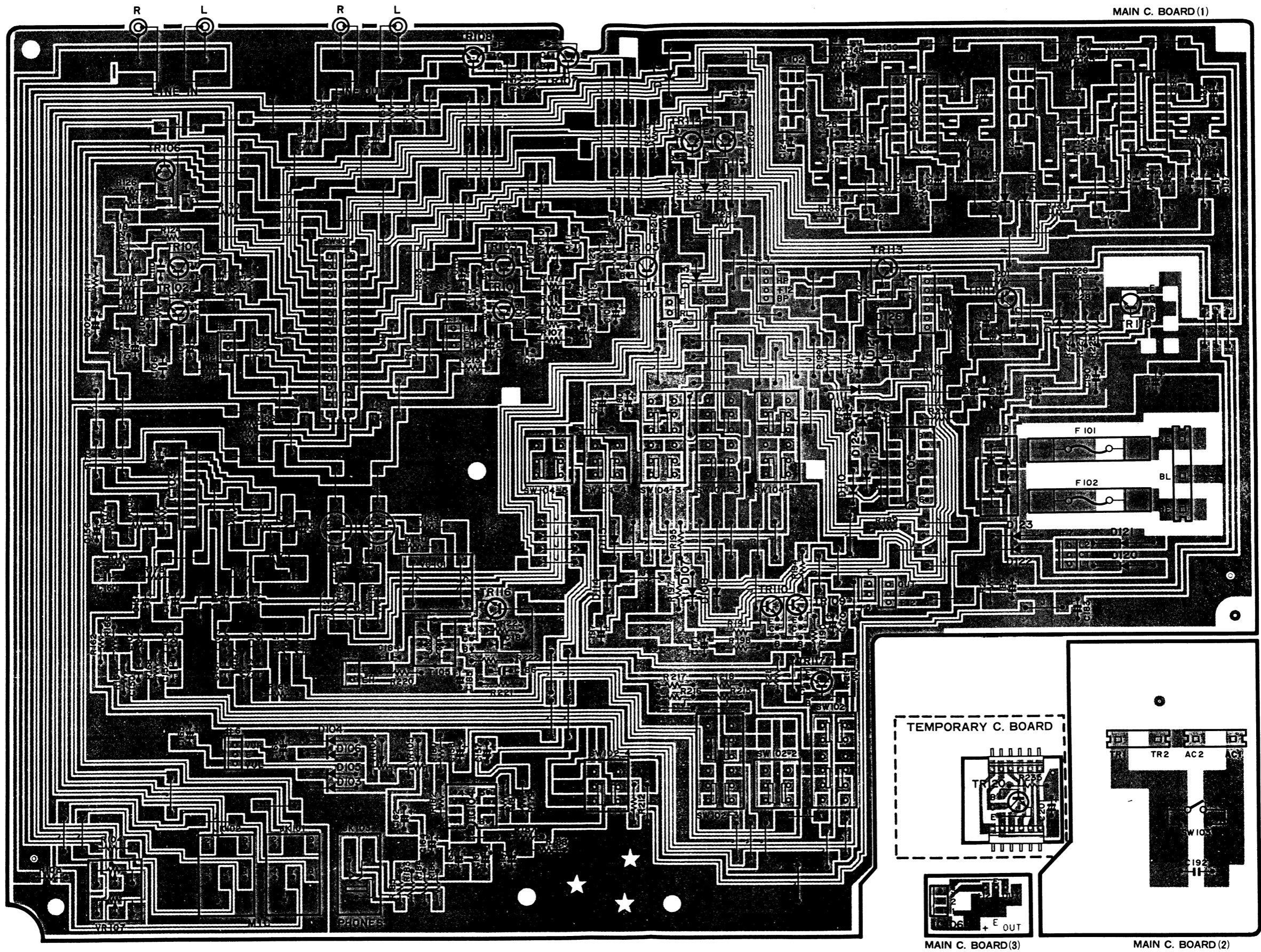



PRINTED CIRCUIT BOARD PARTS-SIDE COMPONENTS LAYOUT/WIRING

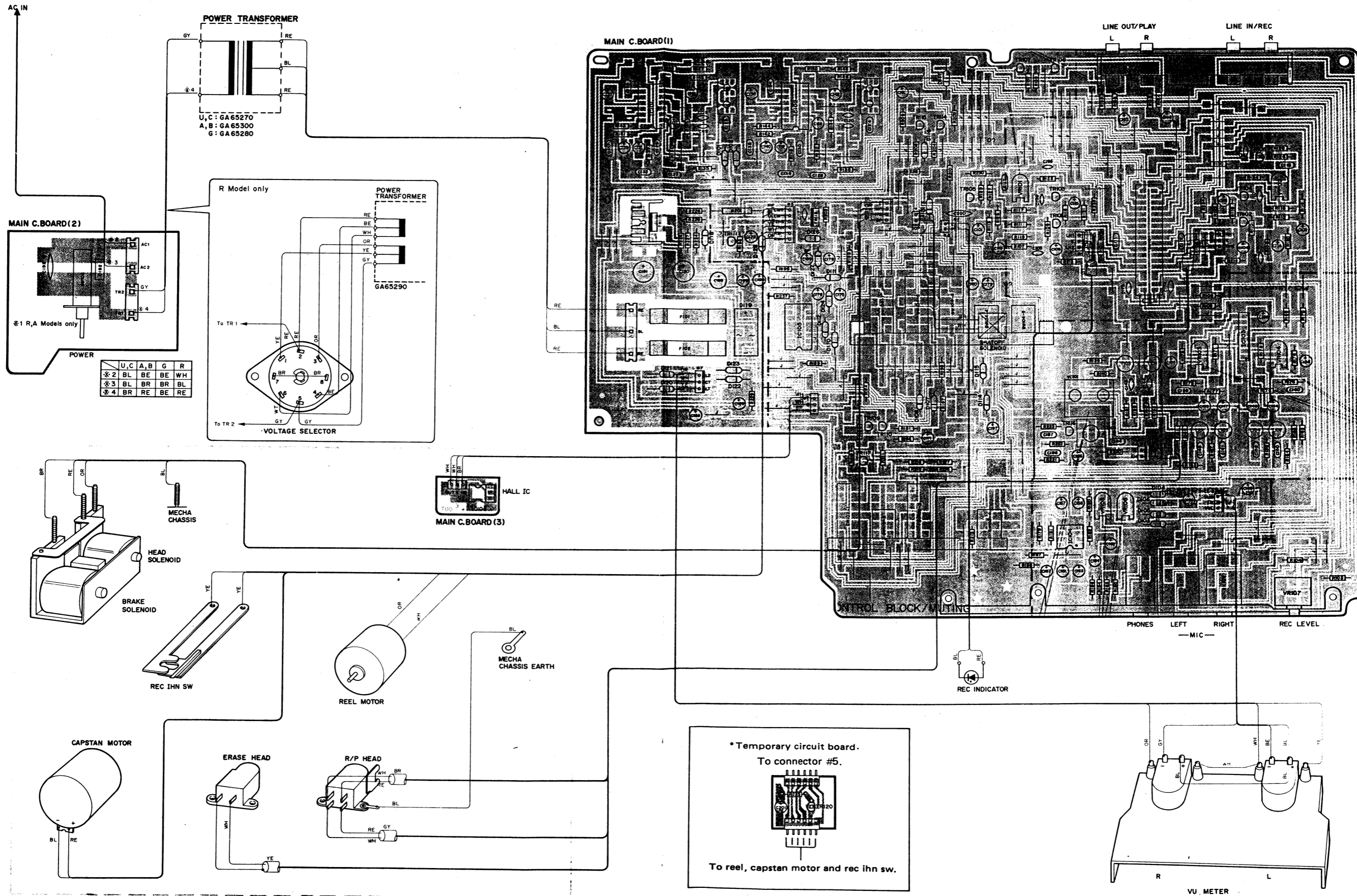

	U	C	A	B	G	R
* 2	BL	BE	BE	WH		
* 3	BL	BR	BR	BL		
* 4	BR	RE	BE	RE		

\* Temporary circuit board.  
To connector #5.  
To reel, capstan motor and rec ihn sw.

# PARTS LIST

## K-200

### STEREO CASSETTE DECK

■CONTENTS	Page
■EXPLODED VIEW(Allover) .....	1
■PARTS LIST (Allover) .....	2
■EXPLODED VIEW (Mechanism) .....	3
■PARTS LIST (Mechanism) .....	4
■PARTS LIST (Circuit Board) Main Circuit Board .....	6

#### Notes

#### DESTINATION ABBREVIATIONS

U .....	U.S.A
C .....	CANADIAN
G .....	EUROPEAN
B .....	BRITISH
R .....	GENERAL
A .....	AUSTRALIAN
J .....	JAPAN

004463

SINCE 1887



# YAMAHA

NIPPON GAKKI CO., LTD. HAMAMATSU, JAPAN

Printed in Japan 5.82  2.65K

# EXPLODED VIEW (Allover)

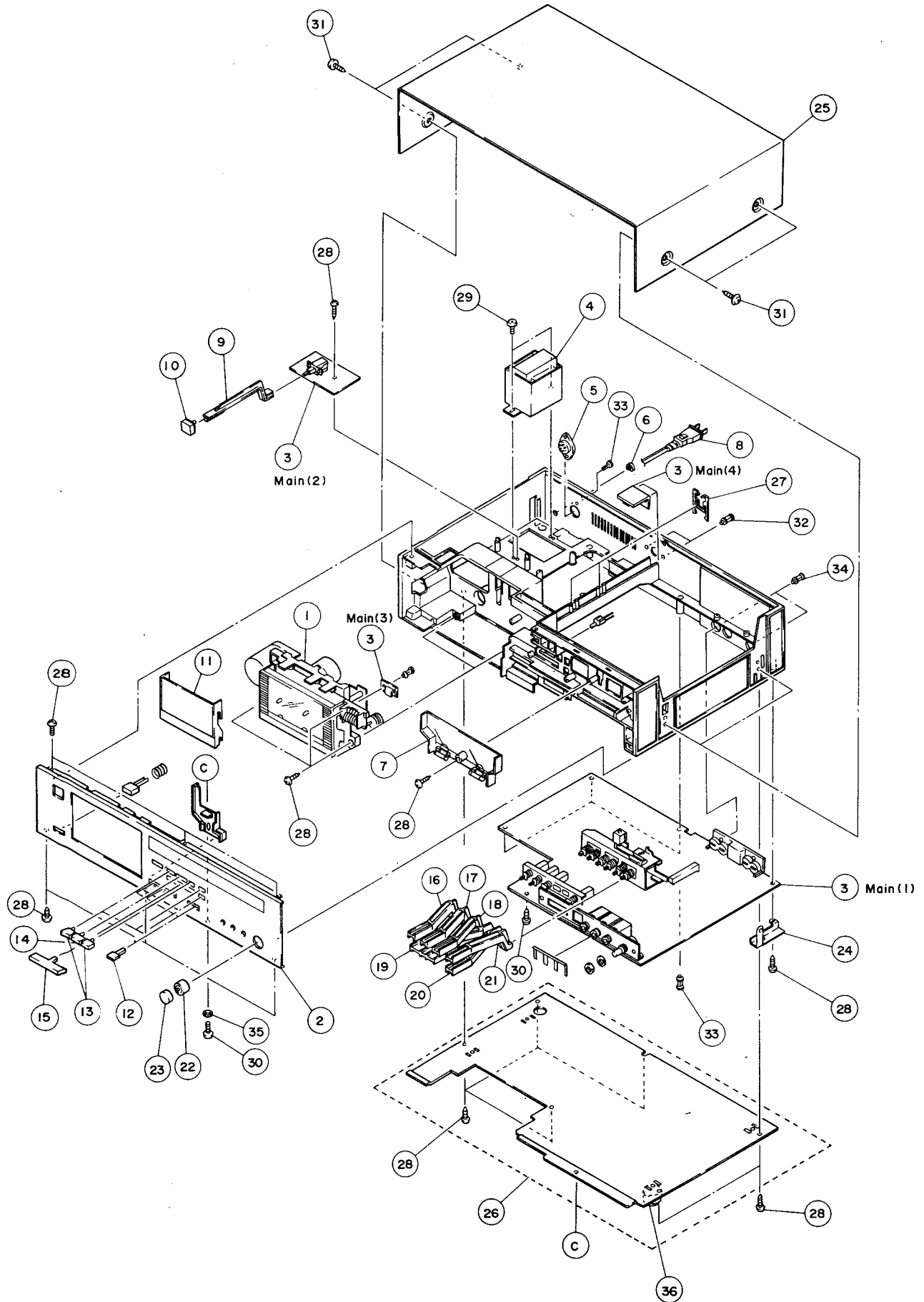



Ref. No.	Part No.	Description	(部 品 名)	Remarks	Common model	Markets
* 1	SM:60:18:00	Cassette Meahanism	TM-5A(S)	カセットメカ総組立		
* "	SM:60:19:00	"	" (B)	"	Black Model	G
* 2	NB:60:57:50	Panel Unit		パネルユニット		
* "	NB:60:57:60	"		"	Black Model	G
* 3	NA:07:89:00	Main Circuit Board		メインシート		J
* "	NA:07:89:10	"		"		U,C
* "	NA:07:89:20	"		"		G,B
* "	NA:07:89:30	"		"		R,A
* "	NA:07:89:40	"		"	Black Model	G
* 4	GA:65:26:00	Power Transformer		電源トランス		J
* "	GA:65:27:00	"		"		UC
* "	GA:65:28:00	"		"		G
* "	GA:65:30:00	"		"		A,B
* "	GA:65:29:00	"		"		R
* 5	LB:20:14:80	Voltage Selector		電圧切替器		R
* 6	CB:06:86:30	Cord Stopper	SR-3P-4	コードストッパー		J,U,C
* "	CB:60:99:50	"	SR-5N-4	"		R,A,G,B
* 7	Ji:00:12:50	VU Meter	(S)	VUメーター		
* "	Ji:00:12:60	"	(B)	"	Black Model	G
* 8	MG:00:04:10	AC Cord	Black 2.2m 7A/125V	電源コード		J
* "	MG:00:07:80	"	" 2m 6A/250V	"		R
* "	MG:00:08:40	"	" " 10A/125V	"	Inter-changeable	U,C
* "	MG:00:12:40	"	" " "	"		U,C
* "	MG:00:09:20	"	Gray 2.5m 7.5A/250V	"		A
* "	MG:00:09:50	"	" 2m 2.5A/250V	"		G
* "	MG:00:10:00	"	Black 2m 6A 300/500V	"		B
* 9	CB:60:80:90	Rod Power		ロッド、POWER		
* 10	CB:61:02:30	Button, Power		パワーボタン		
* "	CB:61:02:40	"		"	Black Model	G
* 11	CB:60:81:00	Lid Cover		リッドカバー		
* "	CB:60:91:30	"		"	Black Model	G
* 12	CB:61:01:30	Push Button		プッシュボタン		
* "	CB:61:01:40	"		"	Black Model	G
* 13	CB:61:01:50	Operation Button A		P-オペボタンA		
* "	CB:61:01:60	" A		" A	Black Model	G
* 14	CB:61:01:70	" B		" B		
* "	CB:61:01:80	" B		" B	Black Model	G
* 15	CB:61:01:90	" C		" C		
* "	CB:61:02:00	" C		" C	Black Model	G
* 16	CB:60:81:50	Rod, REW	#1	ロッド、REW		
* 17	CB:60:81:60	" PLAY	#2	" PLAY		
* 18	CB:60:81:70	" FF	#3	" FF		
* 19	CB:60:81:80	" STOP	#4	" STOP		
* 20	CB:60:81:90	" REC	#6	" REC		
* 21	CB:60:82:00	" MUTE	#5	" MUTE		
* 22	BA:08:24:70	Knob, Bouble L		ダブルツマミL		
* "	BA:08:29:10	" L		" L	Black Model	G
* 23	BA:08:24:80	" R		" R		
* "	BA:08:29:20	" R		" R	Black Model	G
* 24	AA:61:05:70	Metal Fitting		アース金具		
* 25	AA:61:06:10	Top Cover		トップカバー		
* "	AA:61:13:00	"		"	Black Model	G

\* : New Parts (新部品)

Ref. No.	Part No.	Description	(部 品 名)	Remarks	Common model	Markets
* 26	NB:60:69:60	Bottom Cover Unit		ボトムカバーユニット		
* 27	CB:60:99:80	Cord Clamper		コードクランパー		
* 28	Ei:03:01:00	Bind Head Tapping Screw	3×10(ZMC2-Y)	鉄バインドタッピングネジ		
* 29	Ei:04:01:40	"	4×14( " )	"	Power Transstormor	
* 30	EN:13:00:10	"	3×6( " )	"	Type-II	
* 31	EK:63:50:30	B-W Head P-tyte Screw	4×12(FCM3-3g)	鉄B.W Pタイトネジ		Top Cover
* 32	CB:60:92:60	Plastic Rivet	φ3	プラスチックリベット		
* 33	CB:60:32:40	"	φ3.5	"		
* 34	CB:61:04:00	"		"		
* 35	EV:20:03:00	Plain Washer	φ3(ZMC2-Y)	平座金		
* 36	CB:61:03:90	Leg		脚		
* 37	CB:61:22:40	Cushion, C.Board		シートクッション		

\* : New Parts (新部品)

EXPLODED VIEW (Mechanism)

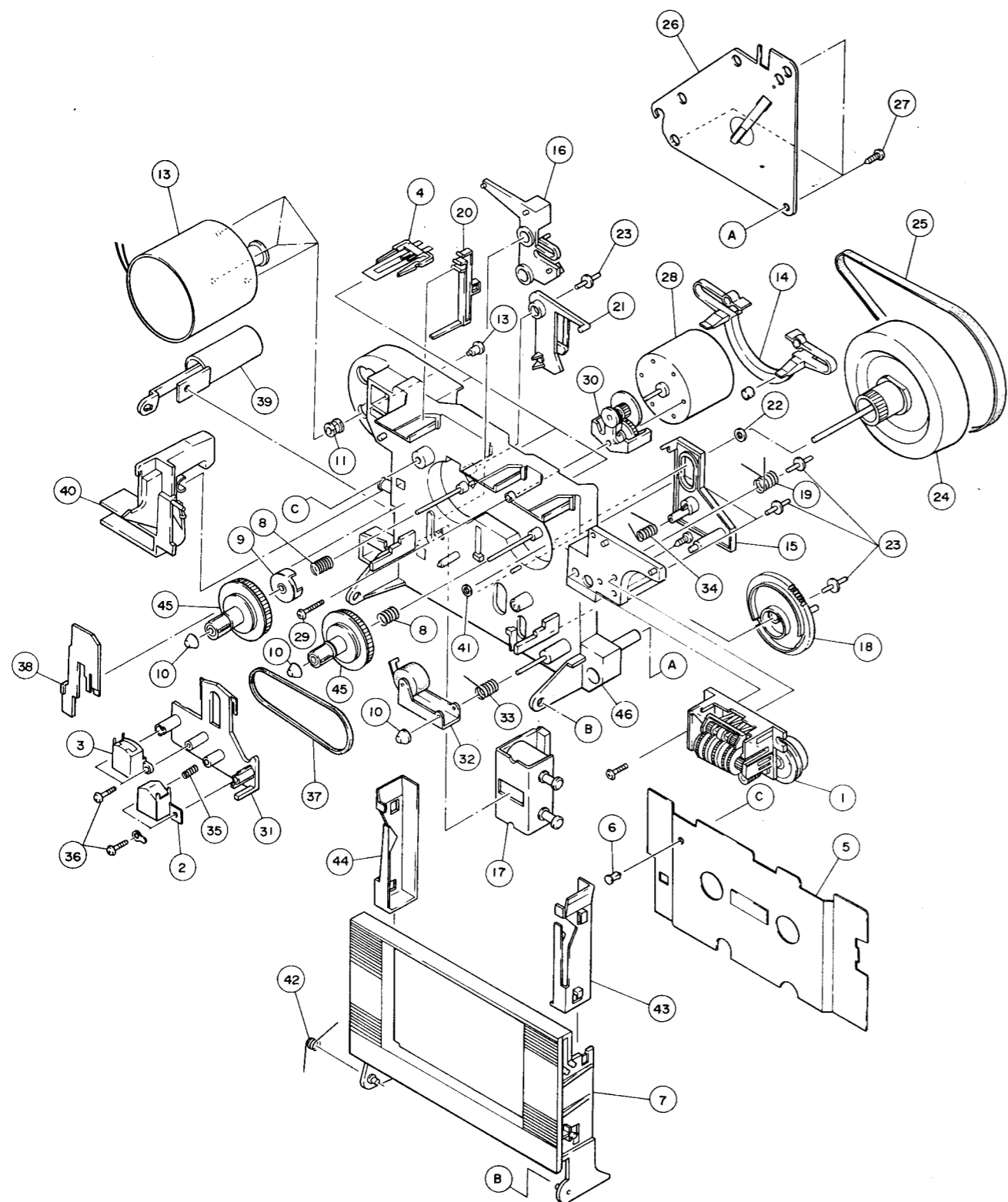

PARTS LIST (Mechanism)

Ref. No.	Part No.	Description	(部 品 名)	Remarks	Common model	Markets
*	SM:60:18:00	Cassette Mechanism	TM-5A(S)	カセットメカ総組立		
*	SM:60:19:00		TM5A(B)	"	Black Model	G
1	PB:06:21:50	Counter		テープカウンター		
2	GF:00:01:90	REC/Playback Head		録再ヘッド		
3	GF:00:01:80	Erase Head		消去ヘッド	K-550 K-560	
4	KA:60:05:20	Leaf Switch		リーフSW		
5	BA:08:18:90	Blind Plate T	N3.5 Gray	ブラインドプレートT		
"	BA:08:28:30	"	N3.5 Black	"	Black Model	G
6	CB:06:88:80	Plastic Rivet	φ3.5 Black	プラスチックリベット		
7	NB:60:58:30	Housing Ass'y	N3 Gray	ハウジングAss'y		
"	NB:60:58:20	"	N3 Black	"	Black Model	G
8	AA:60:88:80	BT-Spring		BT-スプリング		
9	NB:60:33:50	BT-Disc Ass'y		BTディスクAss'y		
10	CB:60:61:50	Reel Cap		リールキャップ		
11	CB:61:11:80	Mounting Plate, Motor		モーター取付座		
12	AA:60:66:50	Screw, Motor	(ZMC2)	モーター取付ネジ	K-550 K-560	
13	JC:00:07:10	Capstan Motor	MMi-6	キャプスタンモーター		
14	NB:60:58:00	Brake Ass'y		ブレーキAss'y		
15	CB:60:61:60	Cam Follower		カムフォロア		
16	CB:60:61:70	Play-Triger		Play-トリガ		
17	JF:00:03:30	Solenoid Ass'y		ソレノイドAss'y		
18	CB:60:61:80	Cam		カム		
19	AA:60:88:90	Cam-Spring		カムスプリング		
20	CB:60:75:90	Senser, Lid		リッドセンサ		
21	CB:60:61:90	Stop-Triger		STOP-トリガ		
22	CB:60:62:10	Washer	PW-2.5-7	ポリスライダワッシャー		
23	CB:60:62:00	Rivet		リベット		
24	NB:60:33:70	Flywheel Ass'y		フライホイールAss'y		
25	CB:60:62:20	Main Belt		メインベルト		
26	NB:60:79:10	Back Plate Ass'y		バックプレートAss'y		
27	Ei:03:01:00	Bind Head Tapping Screw	3×10	鉄バインドタッピングネジ		
28	JC:00:07:20	Reel Motor	BFS9B	リールモーター		
29	ED:02:62:00	Bind Head Screw	2.6×20(ZMC2-Y)	鉄バインド小ネジ		
30	NB:60:33:90	Gear Ass'y		ギヤAss'y		
31	CB:60:62:30	Head Base		ヘッドベース		
32	NB:60:34:00	Pinch Roller Ass'y		ピンチローラーAss'y		
33	AA:60:89:10	Spring, Return		リターンスプリング		
34	AA:60:89:20	" Head Base		ヘッドベーススプリング		
35	AA:60:89:30	" RPH		RPHスプリング		
36	ED:02:01:20	Bind Head Screw	2×12(ZMC2-Y)	鉄バインド小ネジ	R/P Head	
37	CB:60:62:40	Counter-Belt		カウンターベルト		
38	CB:60:61:00	Lever, Play Lock		プレイロックレバー		
39	NB:60:33:40	Damper Ass'y		ダンパーAss'y		
40	CB:60:61:10	Lever, Lock		ロックレバー		
41	CB:08:26:10	Washer		キャプスタンワッシャー	K-550 K-560	
42	AA:60:88:70	Spring, Housing		ハウジングSp		
43	CB:60:98:80	Guide R, Cassette		カセットガイドR		
44	CB:60:98:90	Guide L, Cassette		カセットガイドL		
45	NB:60:34:30	Reel Base Ass'y		リール台Ass'y		
46	NX:60:00:60	Chassis, Mechanism		メカシャーシサブAss'y		
	EJ:02:60:80	Pan Head Tapping Screw	2.6×8(ZMC2-Y)	鉄ナベタッピングネジ	for Tape Counter	

\* : New Parts (新部品)

# ■ PARTS LIST (Circuit Board)

Ref. No.	Part No.	Description	(部 品 名)	Remarks	Common model	Markets
* NA:07:89:00		Main Circuit Board	メインシート			J
* NA:07:89:10						U, C
* NA:07:89:20						G, B
* NA:07:89:30						R, A
NA:07:89:40				Black Model		G
C101 C102	UW:84:71:00	Electrolytic Capacitor	10 $\mu$ F 25V	ケミコン		
C103 C104	FM:51:64:70	"	4.7 $\mu$ F 25V	Zコン		
C105 C106	FG:41:24:70	Ceramic Capacitor	470pF 50V(K)	セラコン		
C109 C110	FG:41:12:20	Ceramic Capacitor	22pF 50V(K)	セラコン		
C111 C112	UA:25:41:20	Mylar Capacitor	0.012 $\mu$ F 50V(J)	マイラーコン		
C113 C114	UW:91:82:20	Electrolytic Capacitor	220 $\mu$ F 6.3V	ケミコン		
C115 C116	UW:84:71:00	"	10 $\mu$ F 25V	"		
C117 C118	UA:25:36:80	Mylar Capacitor	0.0068 $\mu$ F 50V(J)	マイラーコン		
C119 C120	FG:41:21:50	Ceramic Capacitor	150pF 50V(K)	セラコン		
C121 C122	UW:96:54:70	Electrolytic Capacitor	0.47 $\mu$ F 50V	ケミコン		
C123 C124	FG:71:32:70	Mylar Capacitor	0.0027 $\mu$ F 50V(J)	マイラーコン		
C125 C126	FG:41:31:00	Ceramic Capacitor	0.001 $\mu$ F 50V(K)	セラコン		
C127 C128	UA:25:35:60	Mylar Capacitor	0.0056 $\mu$ F 50V(J)	マイラーコン		
C129 C130	UA:25:34:70	"	0.0047 $\mu$ F 50V(J)	"		
C131 C132	UW:84:71:00	Electrolytic Capacitor	10 $\mu$ F 25V	ケミコン		
C133 C134	UA:25:42:70	Mylar Capacitor	0.027 $\mu$ F 50V(J)	マイラーコン		
C135 C136	UW:84:71:00	Electrolytic Capacitor	10 $\mu$ F 25V	ケミコン		
C137 C138	UA:25:51:00	Mylar Capacitor	0.1 $\mu$ F 50V(J)	マイラーコン		
C139 C140	FM:42:53:30	Electrolytic Capacitor	0.33 $\mu$ F 50V	Zコン		
C141 C142	UW:83:82:20	"	220 $\mu$ F 16V	ケミコン		
C143 C144	FG:41:28:20	Ceramic Capacitor	820pF 50V(K)	セラコン		
C145 C146	UW:86:62:20	Electrolytic Capacitor	2.2 $\mu$ F 50V	ケミコン		
C147 C148	UW:86:61:00	"	1 $\mu$ F 50V	"		
C149 C150	UA:25:36:80	Mylar Capacitor	0.0068 $\mu$ F 50V(J)	マイラーコン		
C151 C152	FA:15:33:90	"	0.0039 $\mu$ F 50V(J)	"		
C153 C156	UW:84:71:00	Electrolytic Capacitor	10 $\mu$ F 25V	ケミコン		
C157 C158	UW:86:61:00	"	1 $\mu$ F 50V	"		
C159 C160	UA:25:51:00	Mylar Capacitor	0.1 $\mu$ F 50V(J)	マイラーコン		
C161 C162	UW:96:63:30	Electrolytic Capacitor	3.3 $\mu$ F 50V	ケミコン		
C163 C164	UW:94:72:20	"	22 $\mu$ F 25V	"		
C165 C166	UW:91:74:70	"	47 $\mu$ F 6.3V	"		
C167 C168	UW:84:71:00	"	10 $\mu$ F 25V	"		
C169	UK:16:61:00	"	1 $\mu$ F 50V	B.Pコン		
C170	UW:84:71:00	"	10 $\mu$ F 25V	ケミコン		
C171	UW:91:81:00	"	100 $\mu$ F 6.3V	"		
C172	UW:94:81:00	"	100 $\mu$ F 25V	"		
C173 C174	FG:44:41:00	Ceramic Capacitor	0.01 $\mu$ F 50V(Z)	セラコン		
C175	UW:94:74:70	Electrolytic Capacitor	47 $\mu$ F 25V	ケミコン		
C176	UW:84:71:00	"	10 $\mu$ F 25V	"		
C177	FG:44:41:00	Ceramic Capacitor	0.01 $\mu$ F 50V(Z)	セラコン		
C178	UW:91:83:30	Electrolytic Capacitor	330 $\mu$ F 6.3V	ケミコン		
C179 C180	UW:84:71:00	"	10 $\mu$ F 25V	"		
C182	UW:84:82:20	Electrolytic Capacitor	220 $\mu$ F 25V	ケミコン		
C183	UW:94:64:70	"	4.7 $\mu$ F 25V	"		
* C184	FT:85:32:70	Polypropylene Capacitor	0.0027 $\mu$ F 100V(J)	ポリプロコン ECQ-P		

\* : New Parts (新部品)

Ref. No.	Part No.	Description	(部 品 名)	Remarks	Common model	Markets
C185	UW:94:64:70	Electrolytic Capacitor	4.7 $\mu$ F 25V	ケミコン		
C186	UA:25:41:00	Mylar Capacitor	0.01 $\mu$ F 50V(J)	マイラーコン		
C187	UA:25:42:70	"	0.027 $\mu$ F50V(J)	"		
C188	UW:84:82:20	Electrolytic Capacitor	220 $\mu$ F 25V	ケミコン		
C189	UW:86:61:00	"	1 $\mu$ F 50V	"		
C190	UW:95:91:00	"	1000 $\mu$ F 35V	"		
C191	UW:94:92:20	"	2200 $\mu$ F 25V			
C192	Fi:32:41:00	Ceramic Capacitor	0.01 $\mu$ F AC250V(DE)	セラコン		J
"	Fi:33:41:00	"	0.01 $\mu$ F AC400V(DE)	"		R, A
"	Fi:34:41:00	"	0.01 $\mu$ F MY(DE)	"		U, C
"	FR:16:41:00	MP Capacitor	0.01 $\mu$ F AC250V	MPコン		G, B
C193 C194	UA:25:44:70	Mylar Capacitor	0.047 $\mu$ F 50V(K)	マイラーコン		
C195 C196	FG:41:34:70	Ceramic Capacitor	0.0047 $\mu$ F 50V(K)	セラコン		
C197	UW:84:71:00	Electrolytic Capacitor	10 $\mu$ F 25V	ケミコン		
C198	UW:94:74:70	"	47 $\mu$ F 25V	"		
C199	UW:84:71:00	"	10 $\mu$ F 25V	"		
C200	FG:44:51:00	Ceramic Capacitor	0.1 $\mu$ F 50V(K)	セラコン		
C201	UW:82:81:00	Electrolytic Capacitor	100 $\mu$ F 10V	ケミコン		
* VC101	FY:00:02:10	Trimmer Capacitor	180pF	トリマーコン 2連		
* T101 T102	GE:20:04:10	MPX Coil		MPXコイル		
* T103 T104	GE:90:06:10	Trap Coil	85K	トラップコイル		
* T105	GE:90:06:30	OSC Coil	85K	OSCコイル		
L101 L102	GE:90:02:60	Coil	12mH	固定コイル		
* L103 L104	GE:90:08:10	"	27mH	"		
R101 R102	HJ:35:41:00	Carbon Resistor	10 $\Omega$ RD25S	カーボン抵抗		
R103 R104	HJ:35:73:90	"	39K $\Omega$ "	"		
R105 R106	HJ:35:63:90	"	3.9K $\Omega$ "	"		
R107 R108	HJ:35:76:80	"	68K $\Omega$ "	"		
R109 R110	HJ:35:51:20	"	120 $\Omega$ "	"		
R111 R112	HJ:35:81:50	"	150K $\Omega$ "	"		
R113 R114	HJ:35:61:00	"	1K $\Omega$ "	"		
R115 R116	HJ:35:82:70	"	270K $\Omega$ "	"		
R117 R118	HJ:35:68:20	"	8.2K $\Omega$ "	"		
R119 R120	HJ:35:55:60	"	560 $\Omega$ "	"		
R121 ~124	HJ:35:71:00	"	10K $\Omega$ "	"		
R125 R126	HJ:35:81:00	"	100K $\Omega$ "	"		
R127 R128	HJ:35:68:20	"	8.2K $\Omega$ "	"		
R129 R130	HJ:35:71:00	"	10K $\Omega$ "	"		
R131 R132	HJ:35:61:00	"	1K $\Omega$ "	"		
R133 R134	HJ:35:63:30	"	3.3K $\Omega$ "	"		
R135 R136	HJ:35:51:80	"	180 $\Omega$ "	"		
R137 R138	HJ:35:74:70	"	47K $\Omega$ "	"		
R139 R140	HJ:35:71:00	"	10K $\Omega$ "	"		
R141 R142	HJ:35:81:80	"	180K $\Omega$ "	"		
R143 R144	HJ:35:82:70	"	270K $\Omega$ "	"		
R145 R146	HJ:35:61:00	"	1K $\Omega$ "	"		
R147 ~150	HJ:35:54:70	"	470 $\Omega$ "	"		
R151 R152	HJ:35:63:30	"	3.3K $\Omega$ "	"		
R153 R154	HJ:35:62:20	"	2.2K $\Omega$ "	"		

\* : New Parts (新部品)

Ref. No.	Part No.	Description	(部 品 名)	Remarks	Common model	Markets
R155 -158	HJ 35 71 00	Carbon Resistor	10KΩ RD25S	カーボン抵抗		
R159 R160	HJ 35 63 90	"	3.9KΩ "	"		
R161 R162	HJ 35 72 20	"	22KΩ "	"		
R163 R164	HJ 35 53 30	"	330Ω "	"		
R165 R166	HJ 35 72 70	"	27KΩ "	"		
R167 R168	HJ 35 55 60	"	560Ω "	"		
R169 R170	HJ 35 71 50	"	15KΩ "	"		
R171 R172	HJ 35 62 20	"	2.2KΩ "	"		
R173 R174	HJ 35 64 70	"	4.7KΩ "	"		
R175 -178	HJ 35 72 20	"	22KΩ "	"		
R179 R180	HJ 35 71 00	"	10KΩ "	"		
R181 R182	HJ 35 74 70	"	47KΩ "	"		
R183 R184	HJ 35 61 00	"	1KΩ "	"		
R185 R186	HJ 35 51 80	"	180Ω "	"		
R187 -190	HJ 35 71 00	"	10KΩ "	"		
R191	HJ 35 78 20	"	82KΩ "	"		
R192	HJ 35 64 70	"	4.7KΩ "	"		
R193	HJ 35 62 20	"	2.2KΩ "	"		
R194 R195	HJ 35 61 00	"	1KΩ "	"		
R196	HJ 35 64 70	"	4.7KΩ "	"		
R197	HJ 35 61 50	"	1.5KΩ "	"		
R198	HJ 35 64 70	"	4.7KΩ "	"		
R199	HJ 35 71 00	"	10KΩ "	"		
R201	HL 72 43 90	Metal Oxide Film Resistor	39Ω 2P	酸金被膜抵抗		
R202	HJ 35 63 30	Carbon Resistor	3.3KΩ RD25S	カーボン抵抗		
R204 R205	HJ 35 71 00	Carbon Resistor	10KΩ RD25S	カーボン抵抗		
R208 R209	HJ 35 65 60	Carbon Resistor	5.6KΩ RD25S	カーボン抵抗		
R210	HJ 35 61 80	"	1.8KΩ "	"		
R211	HJ 35 56 80	"	680Ω "	"		
R212	HJ 35 78 20	"	82KΩ "	"		
R213 R214	HJ 35 51 00	"	100Ω "	"		
R215	HJ 35 52 70	"	270Ω "	"		
R216	HJ 35 54 70	"	470Ω "	"		
R217	HJ 35 53 30	"	330Ω "	"		
R218	HJ 35 51 80	"	180Ω "	"		
R219	HJ 35 63 90	"	3.9KΩ "	"		
R220	HJ 35 31 00	"	1Ω "	"		
R221	HJ 35 51 00	"	100Ω "	"		
R222	HJ 35 71 20	"	12KΩ "	"		
R223	HV 35 41 00	Flame Proof Carbon Resistor	10Ω	不燃化カーボン抵抗		
R224	HJ 35 53 30	Carbon Resistor	330Ω RD25S	カーボン抵抗		
R225 -228	HJ 35 61 00	"	1KΩ "	"		
R229	HJ 35 73 30	"	33KΩ "	"		
R230	HJ 35 74 70	"	47KΩ "	"		
R233 R234	HJ 35 62 70	Carbon Resistor	2.7KΩ RD25S	カーボン抵抗		
R235	HJ 35 62 20	"	2.2KΩ "	"		
R236	HJ 35 81 00	"	100K "	"		
R237 R238	HJ 35 61 00	"	1KΩ "	"		

\* : New Parts (新部品)

Ref. No.	Part No.	Description	(部 品 名)	Remarks	Common model	Markets
VR101 VR102	HT 17:02:90	Semi Variable Resistor	B20K V8K4-11	半固定VR	Inter-changeable	
"	HT 37:00:80	"	" EVN-K4A	"		
VR103 -106	HT 17:02:70	Semi Variable Resistor	B5K V8K4-11	半固定VR	Inter-changeable	
"	HT 37:00:50	"	B5K EVN-K4A	"		
* VR107	HS 41:16:00	Variable Resistor	50K×2 2-2	VR 2軸2連		
TR101 -104	i C 23:20:30	Transistor	2SC2320L	トランジスタ		
TR105 TR106	i C 23:20:10	"	2SC2320(E,F)	"	Inter-changeable	
"	i C 26:34:00	"	2SC2634(R,S,T)	"		
TR107 TR108	i D 06:55:00	"	2SD655 (D,E,F)	"		
TR109 TR110	i C 23:20:10	"	2SC2320(E,F)	"	Inter-changeable	
"	i C 26:34:00	"	2SC2634(R,S,T)	"		
TR111	i A 10:20:00	"	2SA1020	"		
TR113	i D 08:80:00	"	2SD880	"		
TR114 TR115	i A 09:99:10	"	2SA999 (E,F)	"	Inter-changeable	
"	i A 11:27:00	"	2SA1127(R,S,T)	"		
* TR116	i C 13:84:00	"	2SC1384	"		
TR117	i D 04:00:00	"	2SD400	"		
TR118	i C 19:83:00	"	2SC1983	"		
TR120	i C 26:55:00	Transistor	2SC2655(O,Y)	トランジスタ		
D101 D102	i F 00:00:40	Diode	IS1555	ダイオード	Inter-changeable	
"	i F 00:06:70	"	IS2473	"		
D103 -106	i F 00:03:30	"	IS188FM1	"		
D107 D108	i F 00:00:40	"	IS1555	"	Inter-changeable	
"	i F 00:06:70	"	IS2473	"		
D110	i F 00:00:40	"	IS1555	"	Inter-changeable	
"	i F 00:06:70	"	IS2473	"		
D111	i H 00:05:90	"	10E-1	"		
D112 -116	i F 00:00:40	"	IS1555	"	Inter-changeable	
"	i F 00:06:70	"	IS2473	"		
D117	i H 00:05:90	"	10E-1	"		
D118	i F 00:16:00	Zener Diode	HZ-18-3	ツェナーダイオード		
D119	i H 00:09:70	Bridge Diode	IS2371A	ダイオードブリッジ		
D120 -123	i H 00:05:90	Diode	10E-1	ダイオード		
D124	i F 00:16:70	Zener Diode	RD6,8EB2	ツェナーダイオード		
D126	i F 00:16:70	Zener Diode	RD6,8EB2	ツェナーダイオード		
* D127	i F 00:38:90	"	HZ4C2	"		
D128	i F 00:00:40	Diode	IS1555	ダイオード	Inter-changeable	
"	i F 00:06:70	"	IS2473	"		
IC101 IC102	i G 03:46:00	IC	NE646N	IC		
IC103	i G 05:82:00	"	M5218L	"		
IC104	i G 04:25:00	"	NJM4556D	"		
* IC105	i G 05:50:00	"	M54532	"		
IC106	i G 03:04:50	"	DN6838	"		
* SW101	KA 40:09:70	Switch, REC/PLAY	12-Circuit	録再スイッチ		
* SW102	KA 80:29:10	Push Switch	4-Action	プッシュSW		
* SW103	KA 80:29:60	Power Switch		パワーSW 4連		J
* "	KA 80:29:70	"		"		U, C
* "	KA 80:29:80	"		"		R, A, G, B,
* SW104	KA 80:29:00	Push Switch	6-Action	プッシュSW 6連		

\* : New Parts (新部品)

Ref. No.	Part No.	Description	(部 品 名)	Remarks	Common model	Markets
F101 F102	KB:00:03:30	Fuse	1A 250V	ヒューズタイラッシュ		J, R, A
"	KB:00:10:60	"	1A 250V UL ST-4	ヒューズ		U, C
"	KB:00:06:70	"	T630mA 250V	ヒューズ <sup>Ⓢ</sup> タイムラグ		G, B,
※ JK101 JK102	LB:30:15:40	Mic Jack		マイクジャック		
※ "	LB:30:16:10	"		"	Black Model	G
※ JK103	LB:30:15:30	Headphones Jack		ヘッドホンジャック		
※ "	LB:30:16:00	"		"	Black Model	G
PJ101	LB:40:08:00	Pin Jack	4P	4Pピンジャック		
	LA:00:21:40	Wrapping Terminal i-type	2P P=10	i型ラッピング端子板		
	LA:00:21:50	"	3P P=10	"		
	LB:20:13:90	Base Pin	2P TEB2P-SHF 2.5 Pitch	2.5ピッチベースピン		
	LB:20:18:80	Fuse Holder Pin	PC-FHI	ヒューズホルダーピン		
	LB:30:07:30	Base Pin	3P TEB3P-SHF 2.5 Pitch	2.5ピッチベースピン		
	LB:40:05:70	"	4P TEB3P-SHF 2.5 Pitch	"		
	LB:60:29:40	"	6P TEB3P-SHF 2.5 Pitch	"		
※	AA:61:05:90	Holder for Main C.B		メインシート金具		
※	AA:61:06:40	Spring, REC Lever		RECレバースプリング		
	BA:08:09:10	Heat Sink		放熱板		K-550
	CB:60:88:10	Plastic Rivet		プラスチックリベット		R-1000
※	CB:60:82:30	Lever, REC		RECレバー		
※	CB:60:82:40	" , S-PL		S-PLレバー		
※	CB:60:99:00	Holder, H-IC		H-ICホルダー		
※	AA:61:05:60	Holder, Switch		SWホルダー		
※	JF:00:03:40	Solenoid	TDS-05B	シャットオフソレノイド		
※	ED:02:00:30	Bind Head Screw	M2×3	バインド小ネジ		
※	ED:03:00:40	"	M3×4	"		
※	ED:03:00:60	"	3×6 (ZMC2-Y)	"		
※	AA:61:12:90	Metal Fitting		PJ金具		
	LB:60:28:20	Base Pin	BS6P-SHF	2.5ピッチベースピン	暫定基板用	
	Mi:07:67:10	Board in & Board in Ass'y	3P ℓ=160	ボードイン&ボードインAss'y		
※	LA:00:37:90	Wrapping Terminal	2P P=10	L型ラッピング端子板		U,C,G,B,
※	Mi:07:64:60	Board in & Board in Ass'y	1P ℓ=100	ボードイン&ボードインAss'y		
		Accessories Ass'y		付属品Ass'y		
	Mi:06:62:10	Cord	1.2m	出力コード(pin-pin)		
※	Mi:08:17:80	"		ミニプラグ付コード	Auto Function	

※ : New Parts (新部品)